

MATERIAL: NYLON 6/6 UL 94 V-2 (RMS-01). COLOR: NATURAL. PART NO.	"A" REF.	"B" REF.
WS-SR-1-01	.45 [11.4]	.17 [4.3]
WS-SR-2-01	.64 [16.3]	.36 [9.1]
WS-SR-3-01	1.00 [25.4]	.73 [18.5]
WS-SR-4-01	1.31 [33.3]	1.04 [26.4]

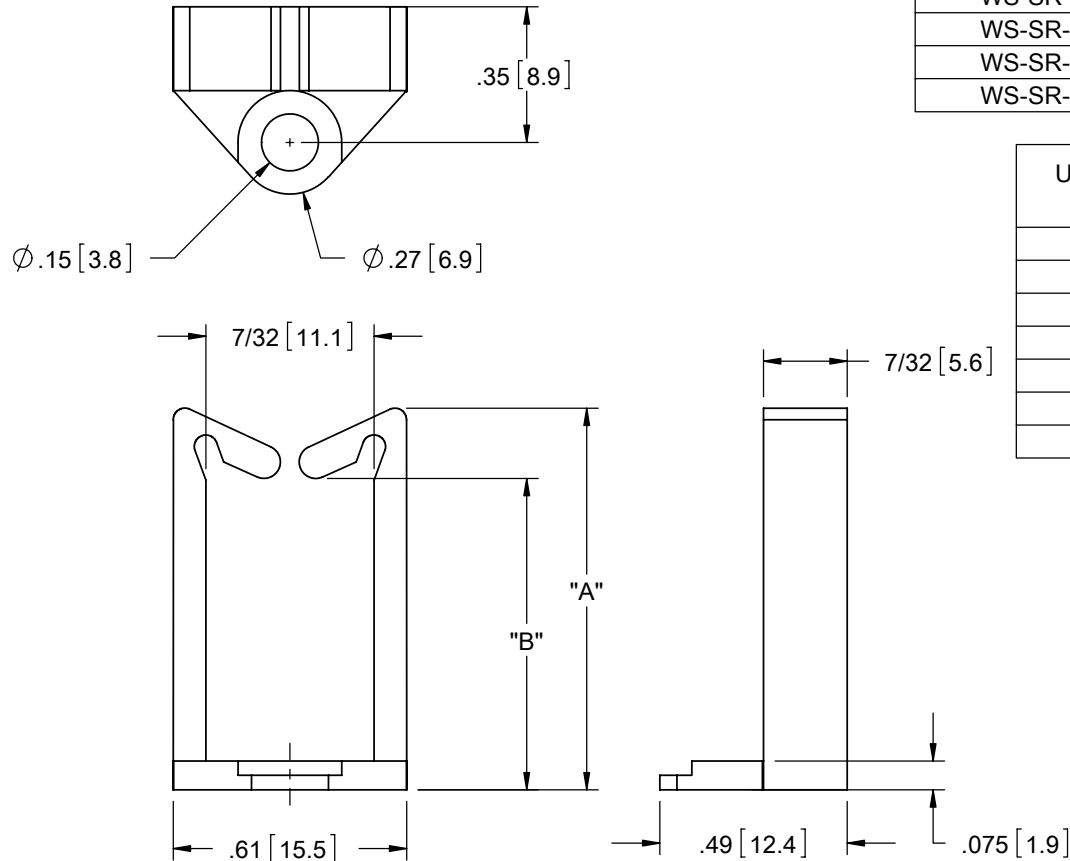

USE RICHCO RIVET NO.	FOR CHASSIS THICKNESS
SR-3535	.010-.046 [0.3-1.2]
SR-3545	.046-.081 [1.2-2.1]
SR-3550	.069-.105 [1.8-2.7]
SR-3555	.081-.120 [2.1-3]
SR-3560	.109-.144 [2.8-3.7]
SR-3570	.140-.180 [3.6-4.6]
SR-3580	.180-.219 [4.6-5.6]

NOTES:

1. MATERIAL: NYLON 6/6 UL 94 V-0 (RMS-19), AVAILABLE BY SPECIAL ORDER ONLY.
MATERIAL: NYLON 4/6 UL 94 V-2 (RMS-109), HEAT RESISTANT, AVAILABLE BY SPECIAL ORDER ONLY.
2. COLOR: NATURAL.
3. FOR PANEL HOLE DIA. .142-.146 [3.6-3.7]

F	SEE ECN #1269 FOR CHANGES	SK	01/08/07
-	SEE ENGINEERING FOR REVISIONS A-E	---	----
REV.	DESCRIPTION	ENGR.	DATE

TITLE: WIRE SADDLE- SNAP RIVET		DWG IN IN [MM]		FINAL		PRINT TYPE	
CREATED USING SOLIDWORKS	FILE #: WS-SR	DWN: SK	APP: RT	PART #		CA	
TOLERANCES UNLESS NOTED .XX=±.010 .XXX=±.005 FRAC.=±1/64 ANG.=±1°	SHEET: 1 OF 1	SHEET SIZE: A	DT: 01/08/07	CHKD: DZ	SEE TABLE		
RE: RICHCO, INC.		RICHCO, INC. ENG@RICHCO-INC.COM (773) 539-4060					